

PARTITION SOUND INSULATION

BASIC 1

ON SINGLE FRAME

from typical technical solutions album of Technosonus and NIISF
version TS/01.2020/RD/S/R4 type S-4.1

components:

- PN 50/40 AcousticGyps reinforced profile
- PS 50/50 AcousticGyps reinforced profile
- V-100 vibrodamping tape
- Sealing tape
- AcousticGyps GKLZ 12.5 mm
- StopZvuk BP/Eco sound-absorbing board
- TS-DG 6/60 Dowel pin · Vibrowasher
- TS-XTN 3.9x23, TS-XTN 3.9x38, TS-MM 4.2-13 self-tapping screws
- Sonetik vibroacoustic sealant
- Bautger glue



SYSTEM
THICKNESS
104 mm



AIRBORNE NOISE
REDUCTION
Rw = 52 dB

The most affordable system with optimal sound insulation indices. For use in apartments, houses, offices as an interior partition.



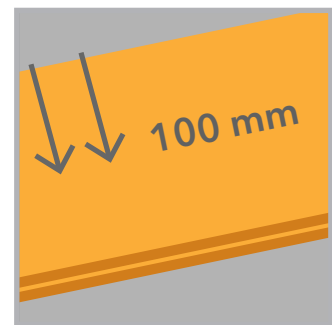
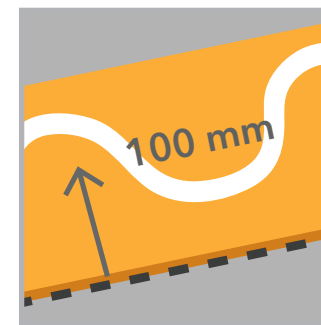
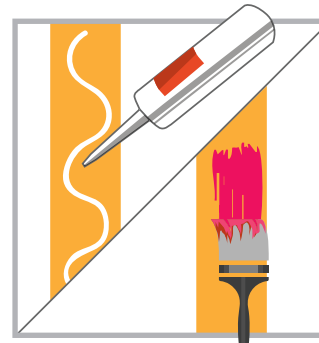
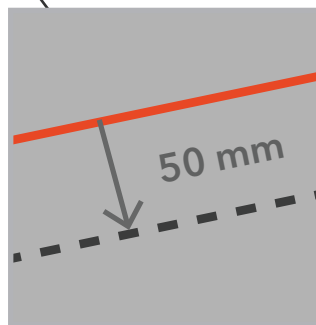
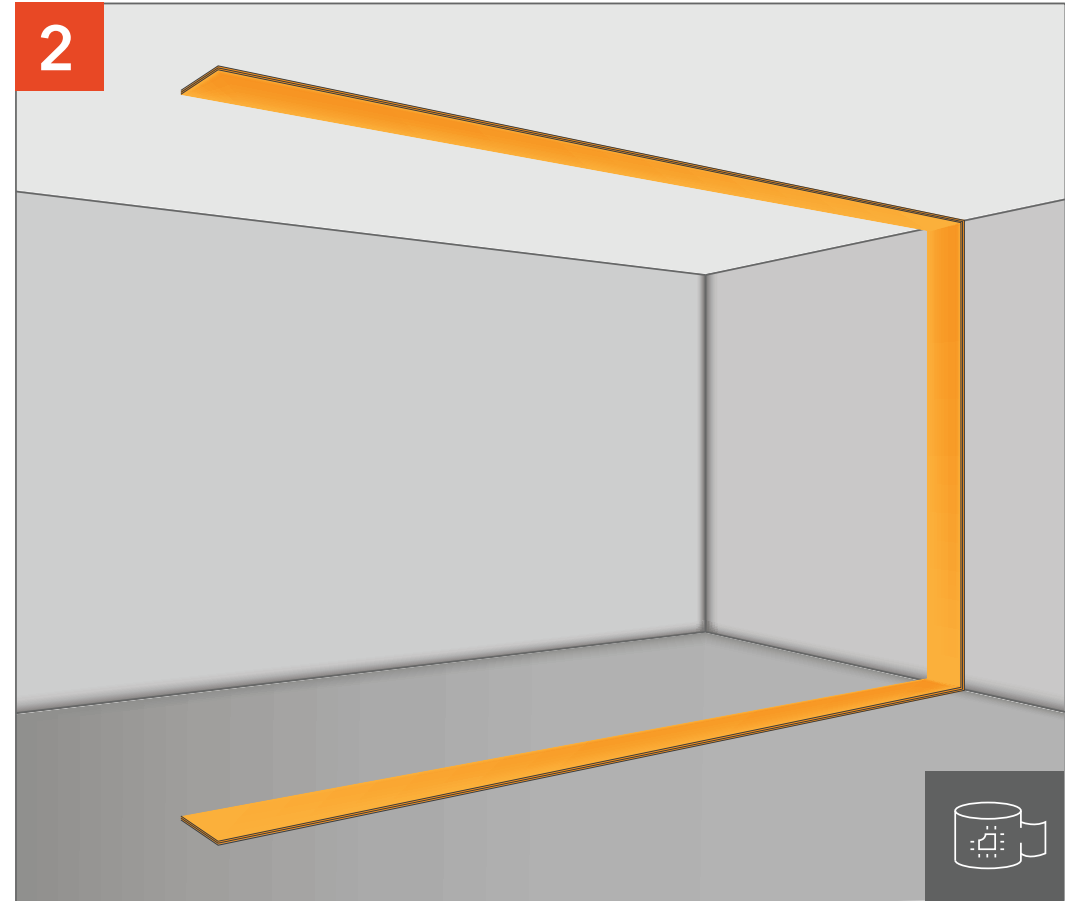
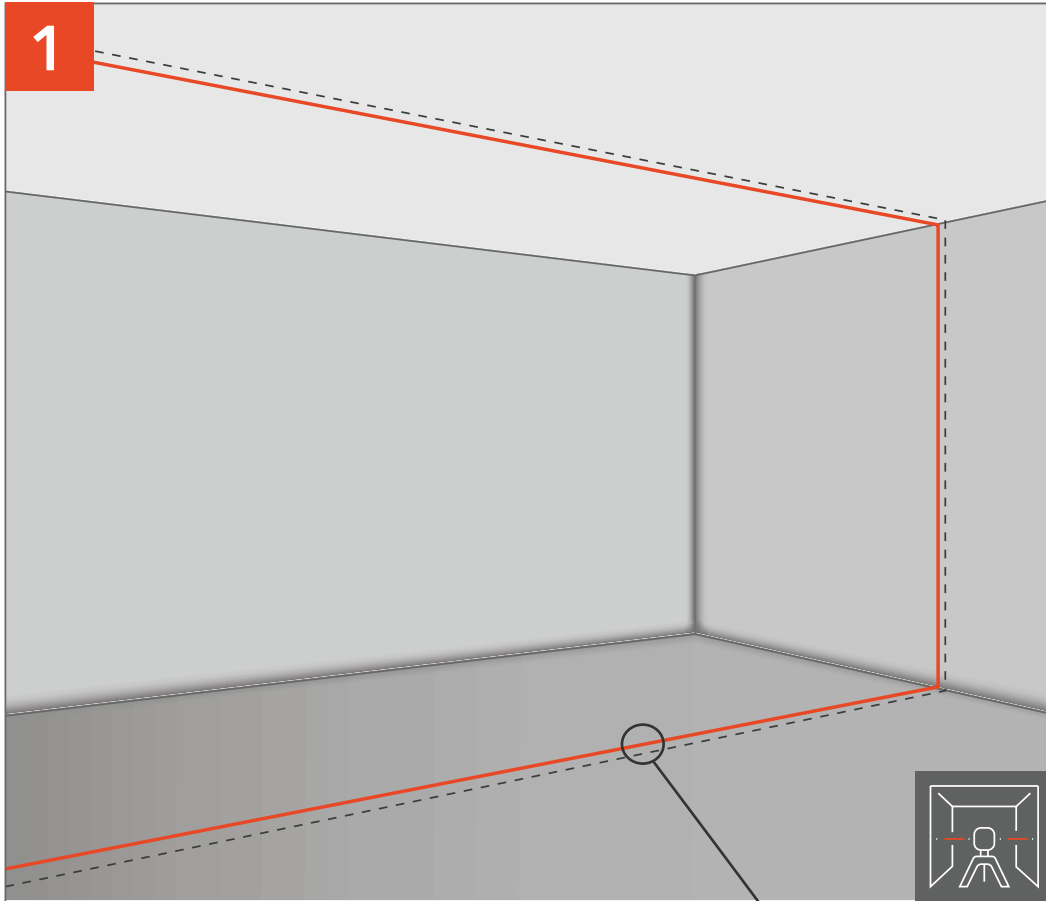

Mark the center line of the partition.

Glue StopZvuk V100 tape using Sonetik vibroacoustic sealant or Bautger glue.

BASIC PARTITION SOUND INSULATION

BASIC PARTITION SOUND INSULATION

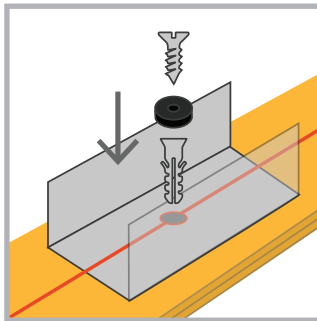
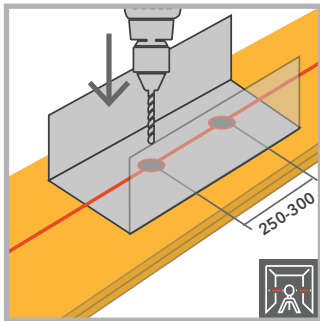
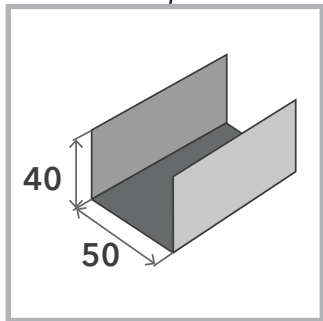
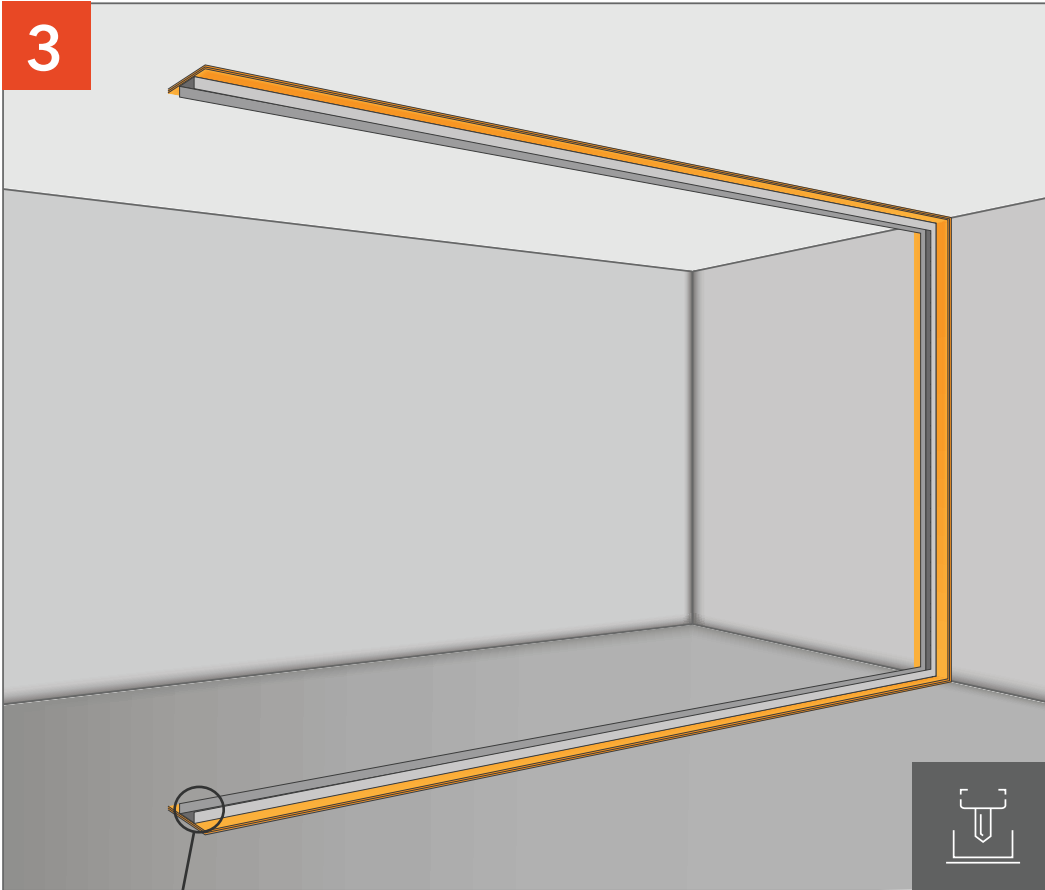

Fasten PN guide profile with 250-300 mm pitch between the dowel pins.

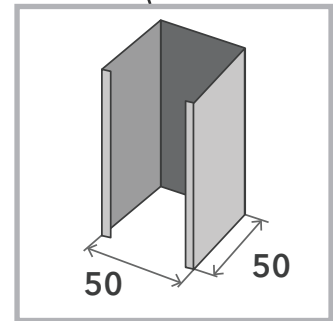
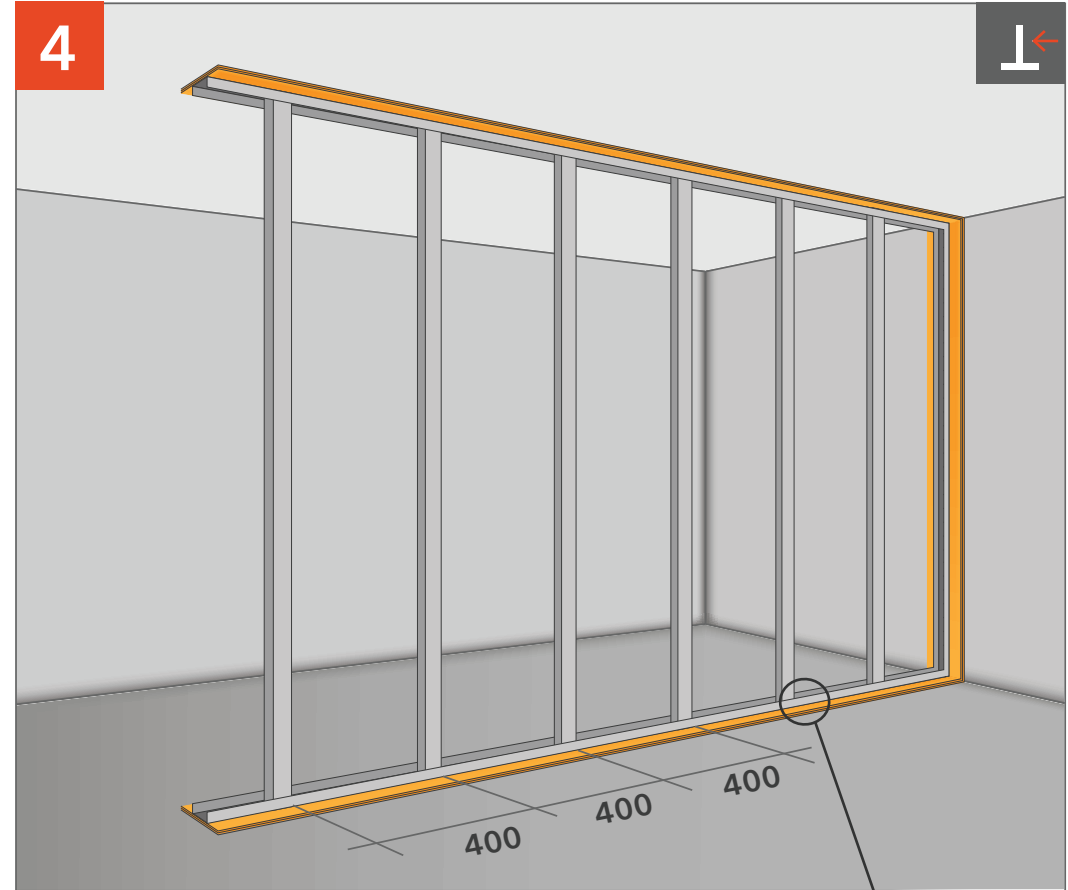

Mount PS stud profile with 400 mm pitch.

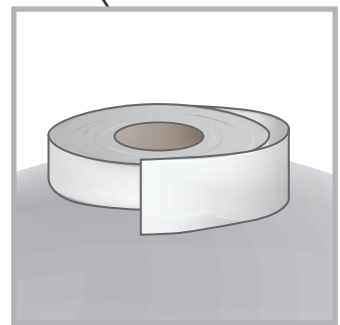
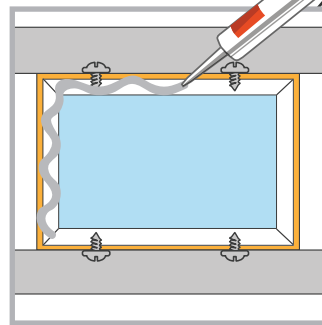
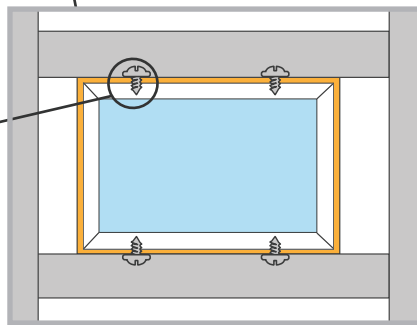
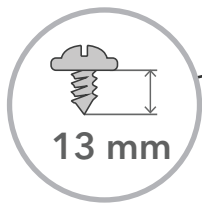
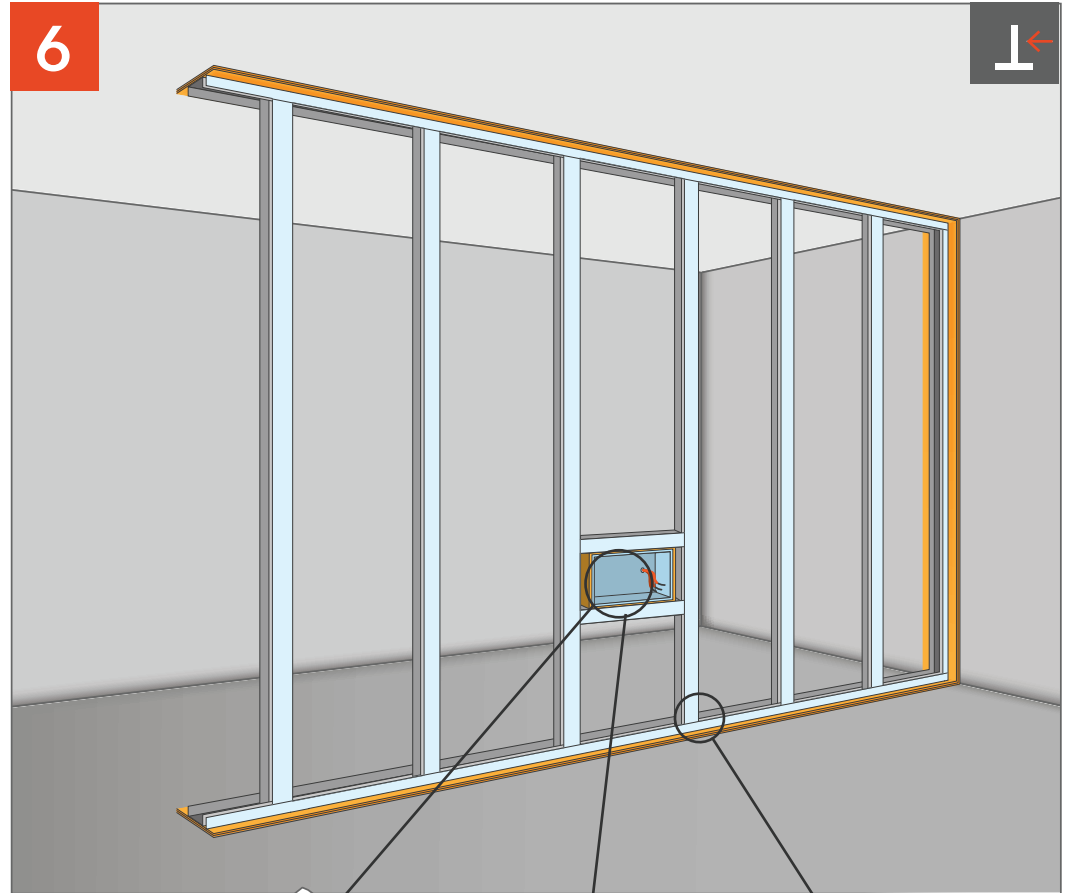
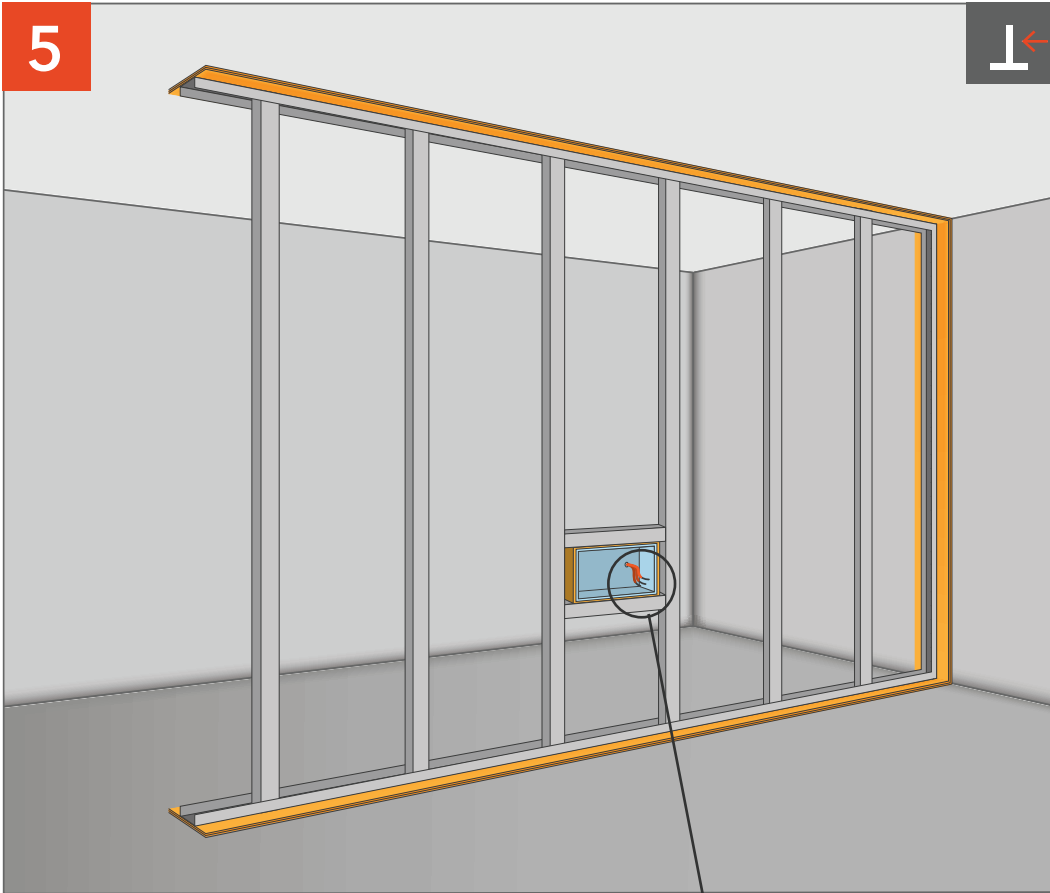

Mount AcousticGypsum Outlet Box in a prepared profile frame.

Glue the frame with damper tape.
Apply Sonetik vibroacoustic sealant to the surface of the outlet box.

BASIC PARTITION SOUND INSULATION

BASIC PARTITION SOUND INSULATION

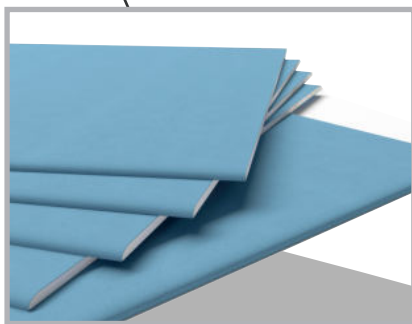
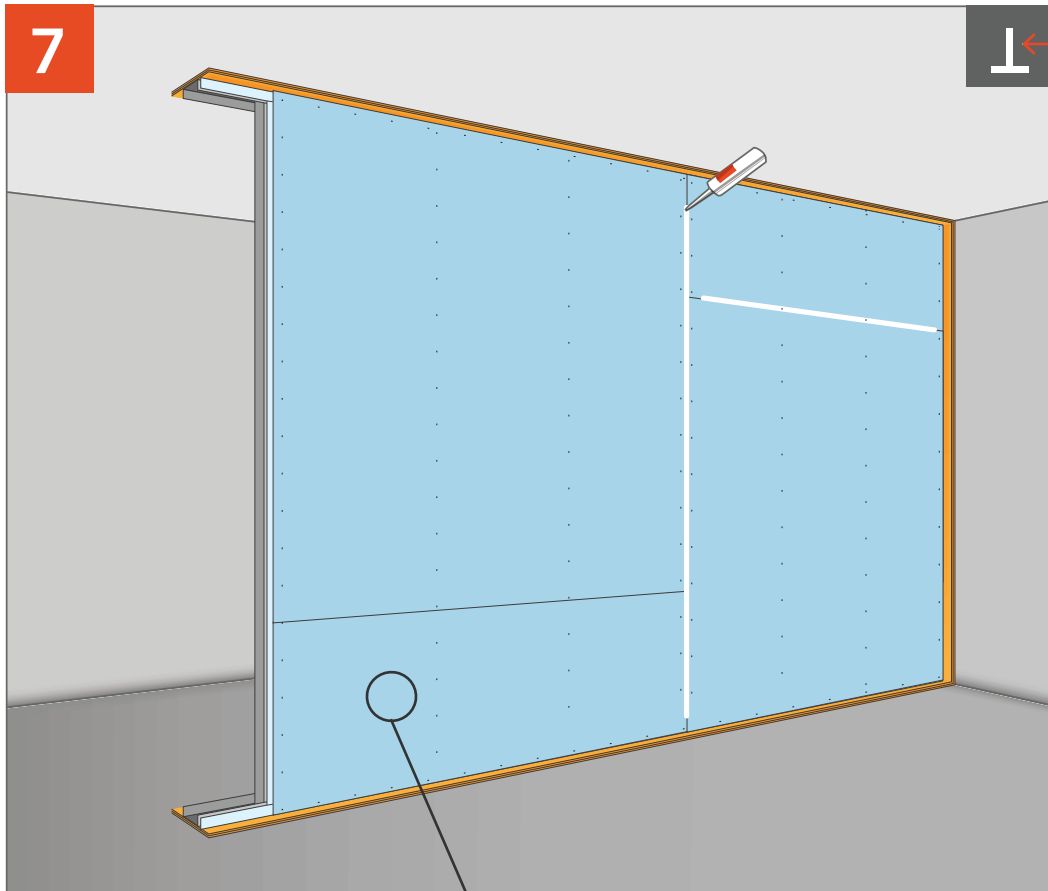

Mount AcousticGyps GKLZ and cover the joints with Sonetik vibroacoustic sealant.

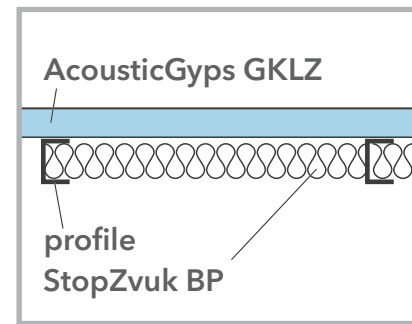
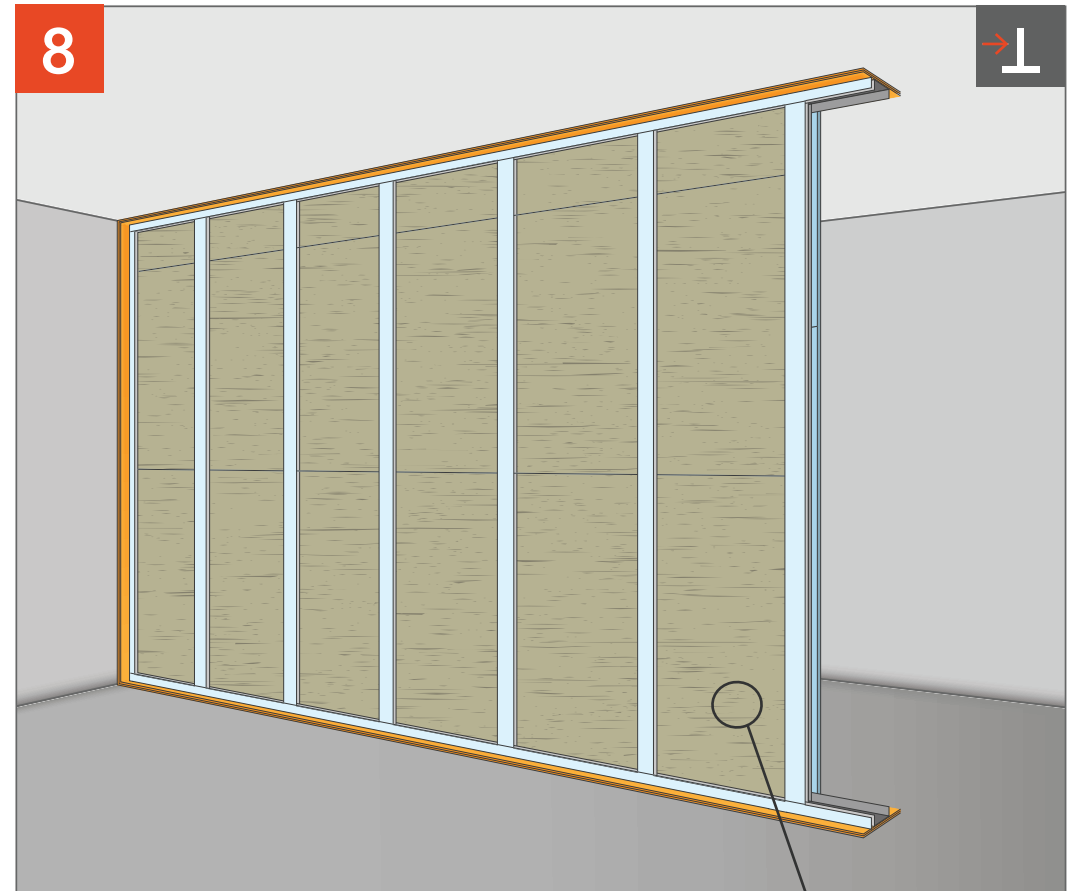

Fill the frame with StopZvuk BP boards.



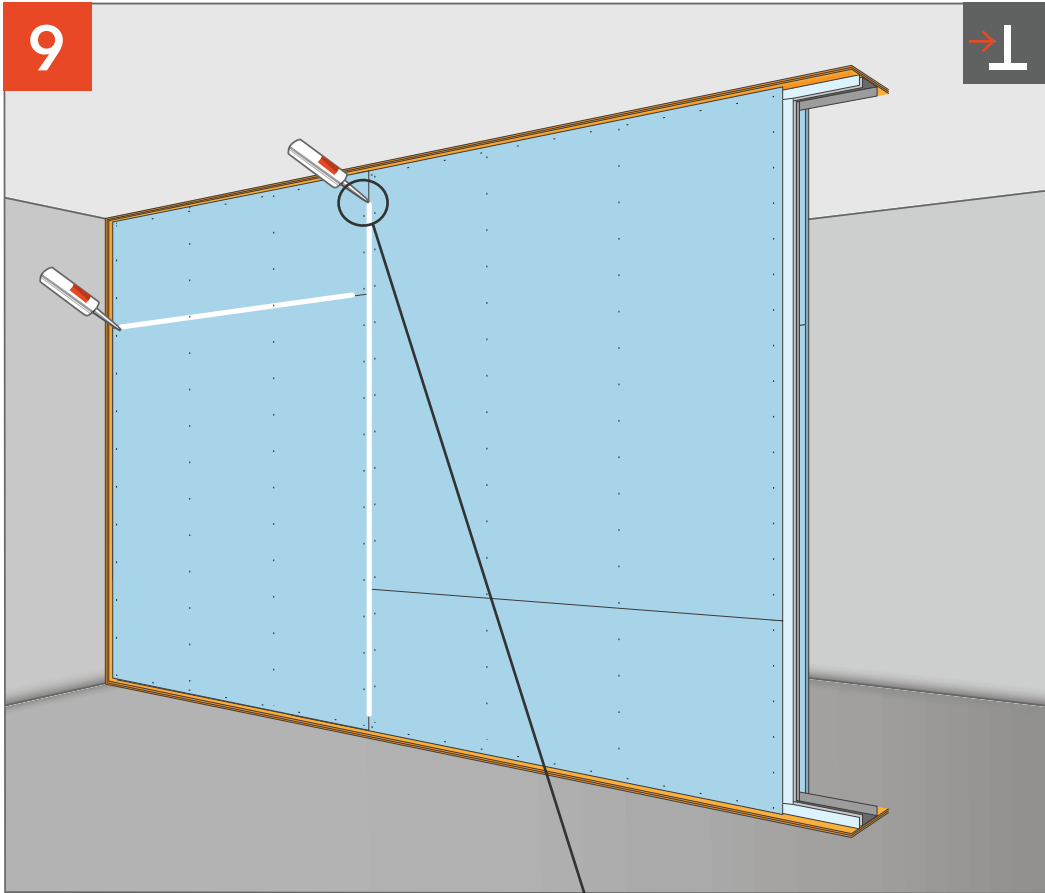

Mount a layer of AcousticGyps GKLZ and cover the seams between the sheets.

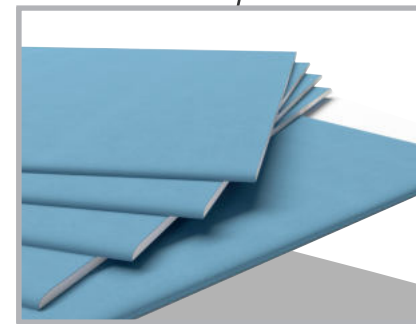
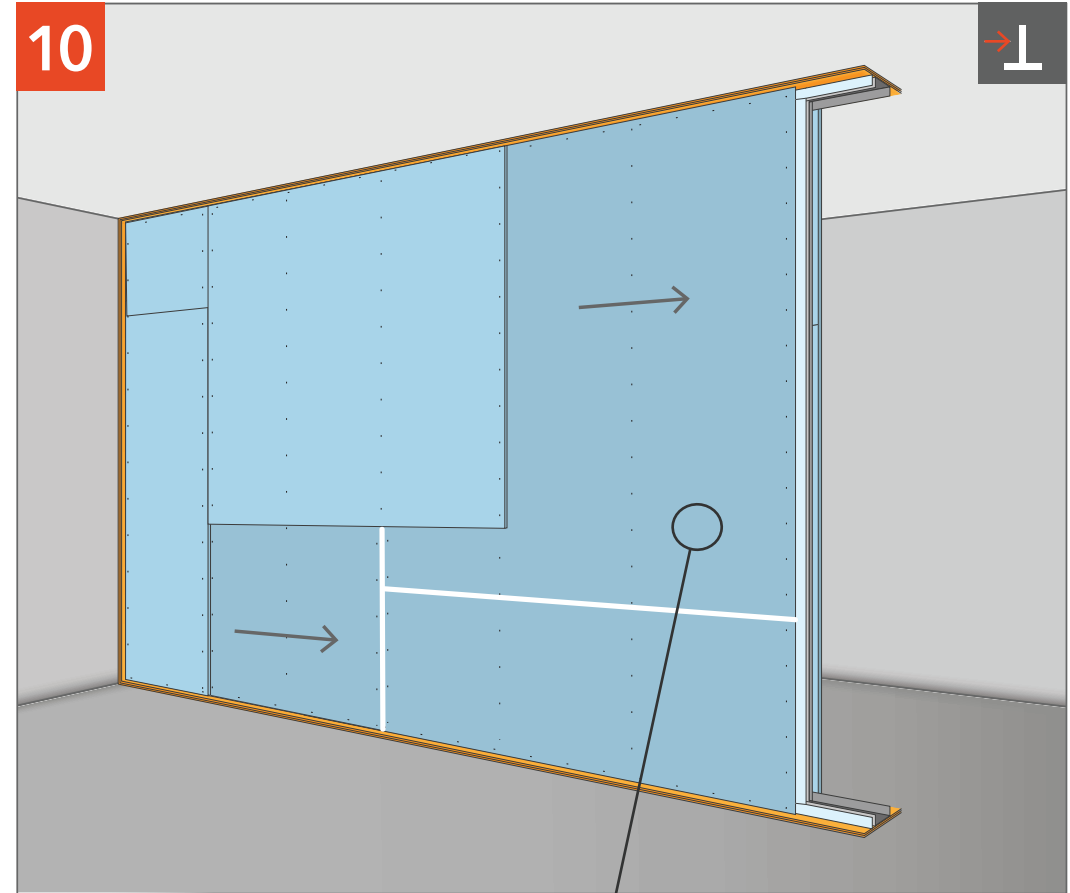

Mount one more AcousticGyps GKLZ layer.

BASIC PARTITION SOUND INSULATION

BASIC PARTITION SOUND INSULATION

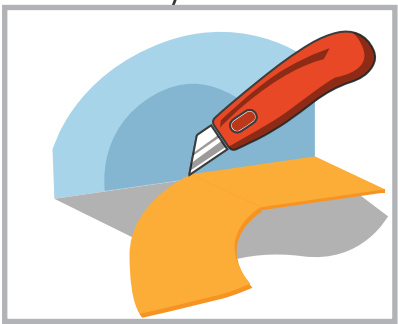
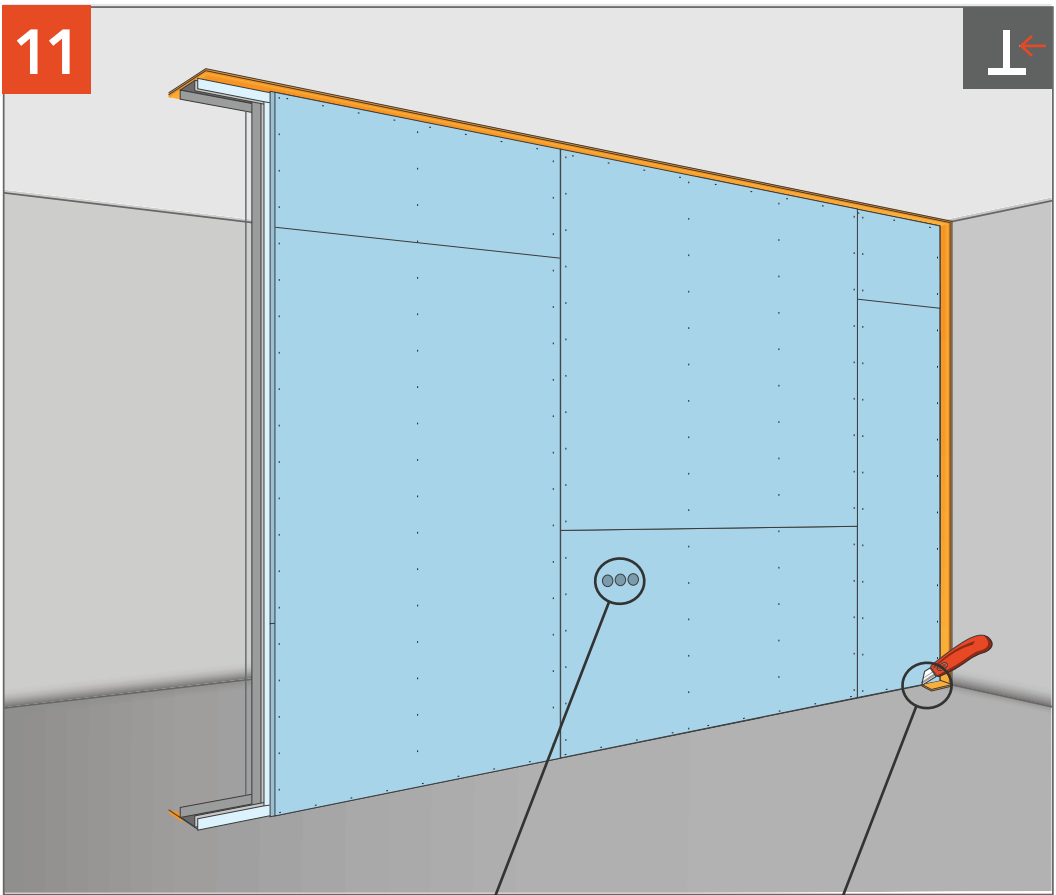

Remove excess of StopZvuk V100 tape.

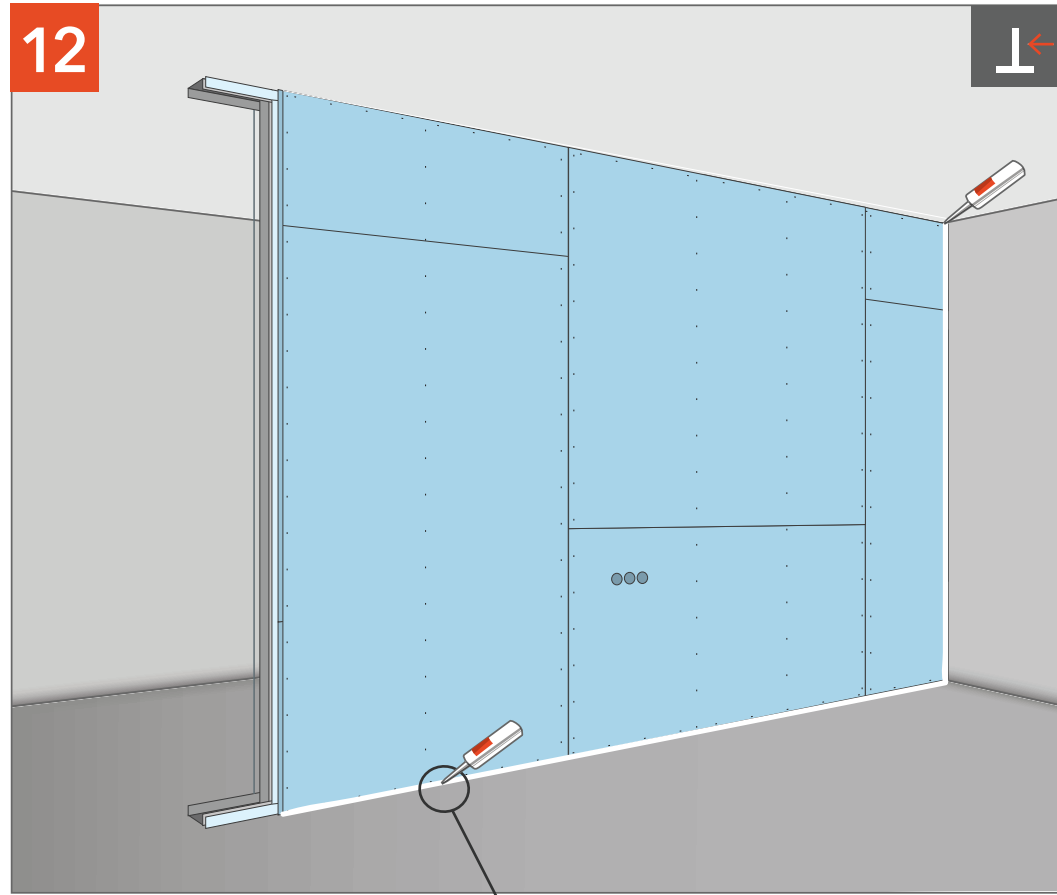

Remove excess of StopZvuk V100 tape and seal the perimeter with Sonetik sealant.